

Energy Bright Limited

P/N: EB-WWS-48-W-AUN-00

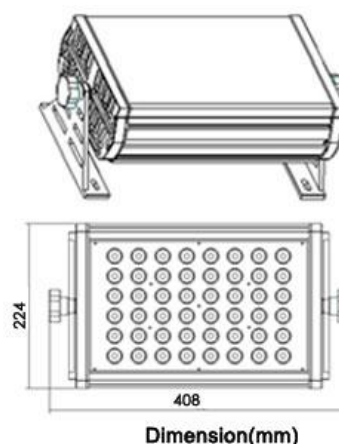

features:

- 1、highlight, high temperature durable toughened glass mirror surface.
- 2、Aluminum alloy Shell.
- 3、support DMX control.
- 4、Level of protection is IP65.

Applications:

- 1、Architecture facade, contour illumination
- 2、Square scenery decoration illumination
- 3、Indoor light design
- 4、Stage & curtain wall light decoration

Product characteristic:

Item	Units	Parameter range
LED Q'ty	PCS	48
Viewing Angle 2θ 1/2(Deg)	angle	$15^{\circ}/30^{\circ}/50^{\circ}$
Dimension	mm	408LX224WX100H
Input voltage	V	100~250
Output power	W	48
Illuminance	LUX	1800
Warranty	1	Year
Life	5	Year

Energy Bright Limited

Taipei Office: 7F, No.15, Lane 427, Fu Shing N.Rd., Taipei Zip code:105

Tel: +886-2-25460395

Fax: +886-2-87707036

Shenzhen Office: Rm 904, Block East, Coastal City, Hai De 3rd Road,

Nan Shan District, ShenZhen City, China Zip code: 518054

Tel: +86-755-83201870

Fax: +86-755-83201877

HK Office: Rm C, 17/FI., Yun Kei Commercial Bldg., 682 Shanghai Street,

Kowloon, Hong Kong .

Tel: +852-23802800 23803600

Fax: +852-23977766

Email: info@energy bright.com www.energy bright.com